

System No. W-L-3309

June 13, 2006

F Ratings – 1 and 2 Hr (See Item 1)

T Rating – 1/2 Hr

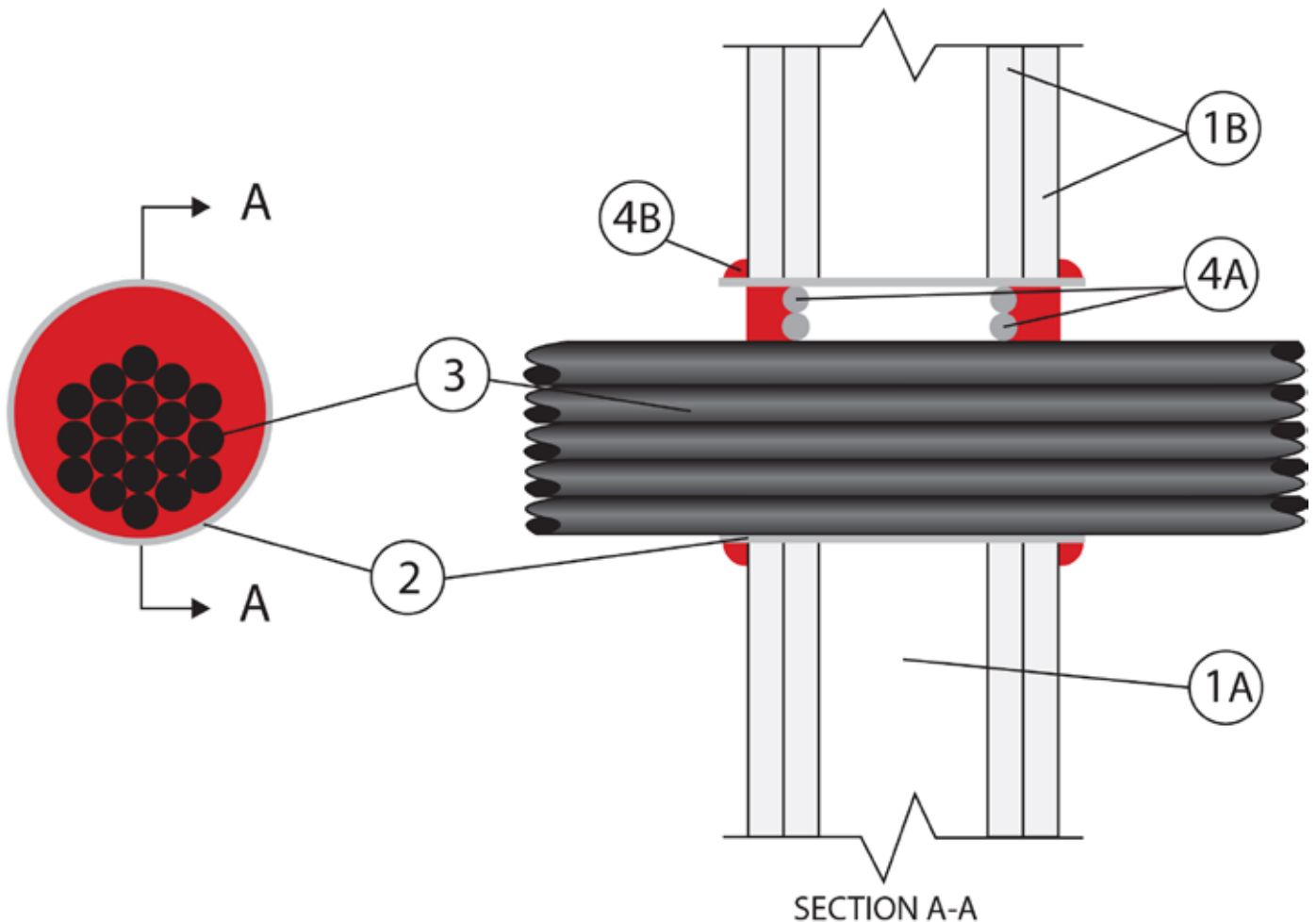

1. Wall Assembly – The 1 or 2 hr fire-rated gypsum board/stud wall assembly shall be constructed of the materials and in the manner specified in the individual U300 or U400 Series Wall and Partition Designs in the UL Fire Resistance Directory and shall include the following construction features:

A. Studs – Wall framing may consist of either wood studs or steel channel studs. Wood studs to consist of nom 2 by 4 in. lumber spaced 16 in. OC. Steel studs to be min 3-1/2 in. wide and spaced max 24 in. OC.

B. Gypsum Board* – One or two layers of nom 5/8 in. thick gypsum board as specified in the individual Wall and Partition Design. Max diam of opening is 4 in.

The hourly F Rating of the firestop system is equal to the hourly fire rating of the wall assembly.

2. Metallic Sleeve – (Optional) – Cylindrical sleeve fabricated from min No. 26 gauge galv sheet steel and having a min 1 in. overlap along the longitudinal seam. Ends of sleeve to be flush with or extend a max 1 in. beyond each surface of wall.

3. Cables – Aggregate cross-sectional area of cables to be min 25 percent to max 64 percent of the aggregate cross-sectional area of the opening. Cables to be tightly bundled and rigidly supported on both sides of wall assembly. The annular space between the cables and the periphery of opening shall be min 0 in. (point contact) to max 2 in. Any combination of following types and sizes of copper conductor cables may be used:

A. Max 2/C with ground, No. 12 AWG MC (BX) cable with polyvinyl chloride (PVC) insulation on conductors inside a steel armored jacket.

B. Max 3/C with ground, No. 12 AWG (or smaller) nonmetallic sheathed (Romex) cable with copper conductors, PVC insulation and jacket.

C. Max 8/C No. 12 AWG (or smaller) Type SOW-A P-123-70-MSHA.

D. Max 25 pair, No. 24 AWG (or smaller) copper conductor telephone cable with XLPE/PVC insulation, with or without PVC jacket.

E. Max RG6 (or smaller) television coaxial cable CATVX.

F. Max 4 pair, No. 24 AWG (or smaller) copper conductor data cable with Hylar insulation and jacketing.

G. Max 1/C, No. 18 AWG (or smaller) Type MTW or THHN or THWN or gas & oil res II 600V (UL) or AWM VW-1 power cable.

H. Max 1/C, No. 14 AWG (or smaller) Type MTW or THHN or THWN or gas & oil res II 600V (UL) or AWM VW-1 power cable.

I. Max 1/C, No. 10 AWG (or smaller) Type THHN or THWN gasoline & oil resistant II 600V VW-1 E116364 (UL) power cable.

J. Optical Fiber Cable max 62.5/125 Type UFNR.

K. Max 3/C, No. 4/0 with ground, AWG aluminum Triple E Alloy AA8176 Type SE cable Style U Type XHH-W-2 CDRS E32071 (UL) service entrance cable.

L. Max 3/C, No. 18 AWG with ground and shield E120910.

4. Firestop System – The firestop system shall consist of the following:

A. Packing Material – For 2 hr wall assemblies, foam backer rod firmly packed into opening as a permanent form. Packing material to be recessed from both surfaces of wall as required to accommodate the required thickness of fill material.

B. Fill, Void or Cavity Material* – Caulk – Min 1/2 in. thickness of fill material applied within the annulus, flush with both surfaces of wall. When steel sleeve is not used or when steel sleeve is flush with the wall surfaces, a min 1/4 in. diam bead of caulk shall be applied at interface of cables and periphery of opening at point contact location on both surfaces of wall. When steel sleeve is used, a bead of caulk is applied to the steel sleeve/gypsum board interface on both sides of wall.

FLAME TECH INC – Firestop-814+

***Bearing the UL Classification Mark**